

Racores rápidos roscados QBM, Quick Basic, mini, NPT

**STASA**

Suministros Industriales del Tajo, S.A.

**FESTO**



## Racores rápidos roscados QBM, Quick Basic, mini, NPT

Datos técnicos

Datos técnicos generales		
Rosca de conexión	UNF	NPT
Tamaño	Mini	
Construcción	Principio Push-Pull (presión y tracción)	
Posición de montaje	Indistinta	
Tipo de junta en el eje roscado	Anillo de junta	Revestimiento

Condiciones de funcionamiento y del entorno		
Presión de funcionamiento [psi] dependiente de la temperatura	-13,8 ... +145	
Fluido de trabajo	Aire comprimido según ISO 8573-1:2010 [7:-:-]	
Temperatura ambiente [°F]	32 ... 140	
Resistencia a la corrosión CRC <sup>1)</sup>	1	

1) Clase de resistencia a la corrosión 1 según norma de Festo 940 070  
Válida para piezas expuestas a peligro de corrosión. Protección para transporte y almacenamiento. Piezas con superficies sin fines decorativos, por ejemplo, por encontrarse en el interior o detrás de tapas o recubrimientos.

### Materiales



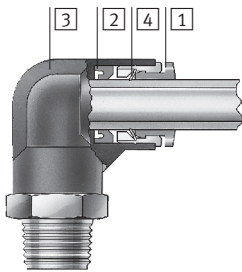





Vista en sección



	QBM
1 Anillo para soltar	POM
2 Junta del tubo flexible	NBR
3 Cuerpo	Latón niquelado PBT
4 Segmento de aprisionamiento del tubo flexible	Acero de aleación fina, inoxidable
Características del material	Contiene sustancias agresivas para la laca Conformidad con RoHS





# Racores rápidos roscados QBM, Quick Basic, mini, NPT

Cuadro general de productos

Forma	Ejecución	Tipo	Conexión D1				Conexión D2			→ Página/ Internet
			Rosca UNF	Rosca NPT	Para tubo de diámetro exterior	Casquillos Diámetro del casquillo	Para tubo de diámetro exterior	Casquillos Diámetro del casquillo		
Forma recta	<b>Racor rápido roscado – Rosca exterior con hexágono exterior</b>									
		QBM	10-32	–	–	–	1/8, 5/32, 1/4	–	5	
			–	1/8			1/8, 5/32, 1/4			
				1/4			1/8, 1/4			
	<b>Racor rápido roscado – Rosca exterior con hexágono interior</b>									
		QBM-...I	10-32	–	–	–	1/8, 5/32, 1/4	–	5	
			–	1/8			1/4			
	<b>Racor rápido roscado – Rosca interior con hexágono exterior</b>									
		QBMF	10-32	–	–	–	1/8, 5/32, 1/4	–	6	
	<b>Racor rápido</b>									
		QBM-...T	–	–	1/8	–	–	–	7	
						5/32				
					1/4					
	QBM-...T Reductor	–	–	5/32	–	1/8	–			
				3/16		1/8				
				1/4		5/32				
<b>Racor con casquillo</b>										
	QBM-...H	–	–	–	5/32	1/8	–	7		
<b>Tapón ciego</b>										
	QBMC-...H	–	–	–	1/8	–	–	8		
En forma de L	<b>Racor rápido roscado en L – Rosca exterior con hexágono exterior</b>									
		QBML	10-32	–	–	–	1/8, 5/32, 1/4	–	9	
			–	1/8			1/8, 1/4			
				1/4			1/8, 1/4			
	<b>Racor rápido roscado largo en L – Rosca exterior con hexágono exterior</b>									
		QBMLL	10-32	–	–	–	1/8, 1/4	–	9	
	–		1/8			1/8, 1/4				
<b>Racor rápido en L</b>										
	QBML-...T	–	–	1/8	–	–	–	10		
					5/32					
					1/4					

## Racores rápidos roscados QBM, Quick Basic, mini, NPT

Cuadro general de productos

Forma	Ejecución	Tipo	Conexión D1				Conexión D2		→ Página/ Internet
			Rosca UNF	Rosca NPT	Para tubo de diámetro exterior	Casquillos Diámetro del casquillo	Para tubo de diámetro exterior	Casquillos Diámetro del casquillo	
En forma de T	<b>Racor rápido roscado en T – Rosca exterior con hexágono exterior</b>								
		QBMT	10-32	–	–	–	1/8, 5/32, 1/4	–	11
				1/8			1/8, 1/4		
				1/4			1/4		
	<b>Racor rápido en T</b>								
		QBMT-...T	–	–	1/8	–	–	–	12
					5/32				
					1/4				
		QBMT-...T Reductor	–	–	5/32	–	1/8	–	
					1/4		5/32		
<b>Racor rápido roscado en T – Rosca exterior con hexágono exterior</b>									
	QBMTL	10-32	–	–	–	1/8, 5/32, 1/4	–	13	
			1/8			1/8, 1/4			
			1/4			1/8			
En forma de Y	<b>Racor rápido en Y</b>								
		QBMY-...T	–	–	1/8	–	–	–	14
					5/32				
					1/4				
	QBMY-...T Reductor	–	–	5/32	–	1/8	–		
				1/4		5/32			

# Racores rápidos roscados QBM, Quick Basic, mini, NPT

Hoja de datos

## Racor rápido roscado QBM

Rosca exterior  
con hexágono exterior

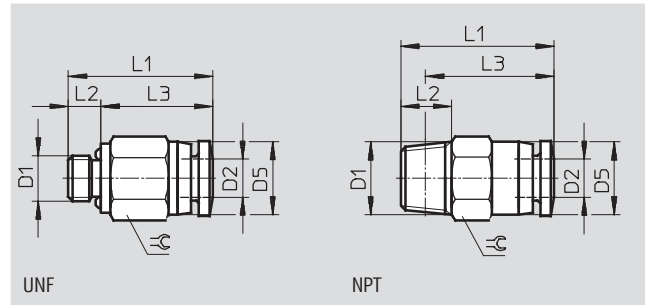

Dimensiones y referencias											
Conexión	Diámetro nominal	Para tubo de diámetro exterior	D5 Ø	L1	L2	L3	≈	Peso/unidad	Nº art.	Tipo	PE <sup>1)</sup>
D1	[pulgadas]	D2						[oz]			
Rosca UNF											
10-32	0,079	1/8	7,2	16,4	3,6	12,8	5/16	0,071	533266	QBM-10-32-UNF-1/8-U	10
	0,098	5/32	8,0	16,9	3,6	13,3	5/16	0,106	572303	QBM-10-32-UNF-5/32-U	10
	0,098	1/4	10,5	18,9	3,6	15,3	7/16	0,353	573050	QBM-10-32-UNF-1/4-U	10
Rosca NPT											
1/8	0,098	1/8	7,2	17,5	8,5	13,4	7/16	0,212	533270	QBM-1/8-1/8-U	10
	0,118	5/32	8,0	17,9	8,5	13,8	7/16	0,317	572305	QBM-1/8-5/32-U	10
	0,197	1/4	10,5	19,5	8,5	15,4	7/16	0,635	573051	QBM-1/8-1/4-U	10
1/4	0,098	1/8	7,2	21,5	10,5	15,7	9/16	0,529	572306	QBM-1/4-1/8-U	10
	0,197	1/4	10,5	22,3	10,5	16,5	9/16	1,023	573052	QBM-1/4-1/4-U	10

1) Cantidad por unidad de embalaje

## Racor rápido roscado QBM-...-I

Rosca exterior  
con hexágono interior

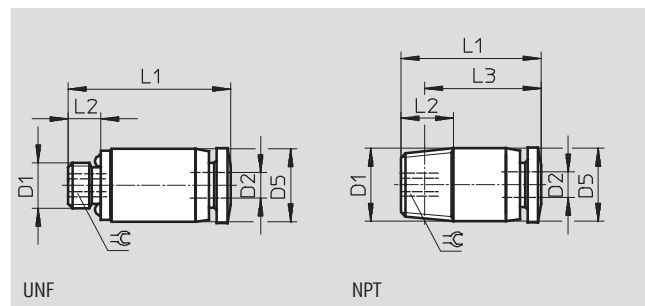

Dimensiones y referencias											
Conexión	Diámetro nominal	Para tubo de diámetro exterior	D5 Ø	L1	L2	L3	≈	Peso/unidad	Nº art.	Tipo	PE <sup>1)</sup>
D1	[pulgadas]	D2						[oz]			
Rosca UNF											
10-32	0,094	1/8	7,0	16,4	3,6	-	3/32	0,071	572311	QBM-10-32-UNF-1/8-I-U	10
	0,094	5/32	8,0	17,0	3,6	-	3/32	0,106	572312	QBM-10-32-UNF-5/32-I-U	10
	0,094	1/4	10,5	19,0	3,6	-	3/32	0,423	573054	QBM-10-32-UNF-1/4-I-U	10
Rosca NPT											
1/8	0,157	1/4	10,5	19,5	8,5	15,4	3/32	0,635	573055	QBM-1/8-1/4-I-U	10

1) Cantidad por unidad de embalaje

## Racores rápidos roscados QBM, Quick Basic, mini, NPT

Hoja de datos

### Racor rápido roscado QBMF

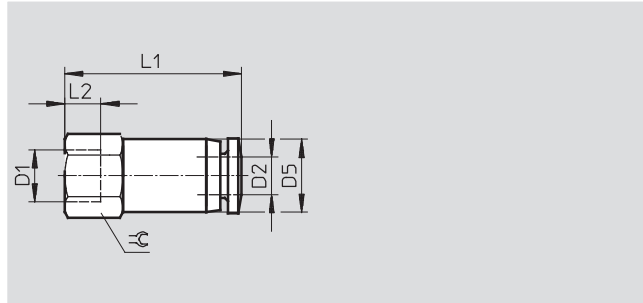

Dimensiones y referencias										
Conexión	Diámetro nominal	Para tubo de diámetro exterior	D5 ∅	L1	L2	≈	Peso/ unidad	Nº art.	Tipo	PE <sup>1)</sup>
D1	[pulgadas]	D2					[oz]			
Rosca UNF										
10-32	0,098	1/8	7,5	18,8	6,0	5/16	0,071	572282	QBMF-10-32-UNF-1/8-U	10
	0,118	5/32	8,0	19,2	6,0	5/16	0,176	572283	QBMF-10-32-UNF-5/32-U	10
	0,118	1/4	10,5	20,5	6,0	7/16	0,212	573066	QBMF-10-32-UNF-1/4-U	10

1) Cantidad por unidad de embalaje

# Racores rápidos roscados QBM, Quick Basic, mini, NPT

Hoja de datos

## Racor rápido QBM-...T

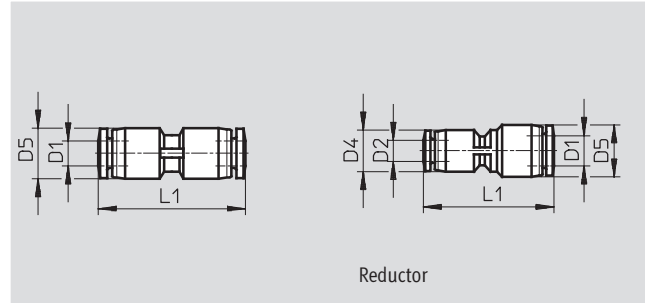

Dimensiones y referencias									
Para tubo de Diámetro exterior D1	Diámetro nominal [pulgadas]	Para tubo de diámetro exterior D2	D4 Ø	D5 Ø	L1	Peso/unidad [oz]	Nº art.	Tipo	PE <sup>1)</sup>
1/8	0,094	-	-	7,5	23,6	0,035	572277	QBM-1/8T-U	10
5/32	0,118	-	-	8,4	24,5	0,071	572278	QBM-5/32T-U	10
1/4	0,197	-	-	11,2	28,6	0,106	573056	QBM-1/4T-U	10
Reductor									
5/32	0,094	1/8	7,5	8,4	24,1	0,071	572279	QBM-5/32T-1/8-U	10
3/16	0,098		7,5	11,5	28,7	0,106	573057	QBM-3/16T-1/8-U	10
1/4	0,138	5/32	8,8	11,2	28,1	0,106	573058	QBM-1/4T-5/32-U	10

1) Cantidad por unidad de embalaje

## Racor rápido QBM-...H

Con casquillo

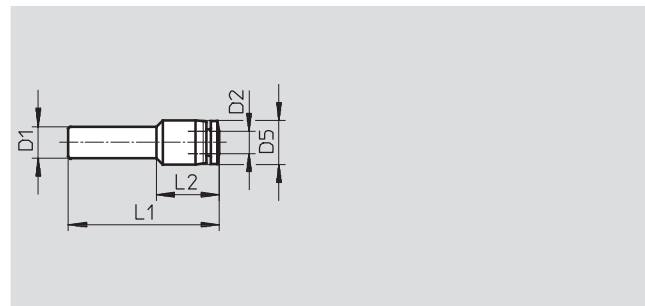

Dimensiones y referencias									
Diámetro del casquillo D1	Diámetro nominal [pulgadas]	Para tubo de diámetro exterior D2	D5 Ø	L1	L2	Peso/unidad [oz]	Nº art.	Tipo	PE <sup>1)</sup>
5/32	0,094	1/8	7,6	30,4	12,4	0,035	572280	QBM-5/32H-1/8-U	10

1) Cantidad por unidad de embalaje

 Nuevo

## Racores rápidos roscados QBM, Quick Basic, mini, NPT

FESTO

Hoja de datos

Tapón ciego QBMC-...H

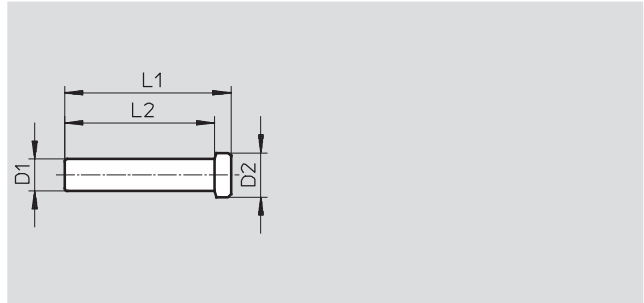

Dimensiones y referencias							
Diámetro del casquillo enchufable	D2	L1	L2	Peso/unidad	Nº art.	Tipo	PE <sup>1)</sup>
D1	∅			[oz]			
1/8	5,0	20,0	18,0	0,035	572281	QBMC-1/8H-U	10

1) Cantidad por unidad de embalaje



# Racores rápidos roscados QBM, Quick Basic, mini, NPT

Hoja de datos

## Racor rápido roscado en L QBML

Rosca exterior  
con hexágono exterior

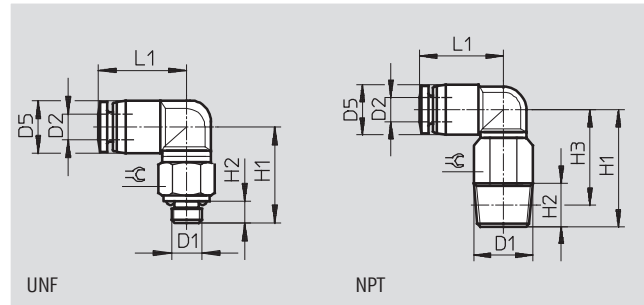

Dimensiones y referencias												
Conexión	Diámetro nominal	Para tubo de diámetro exterior	D5 ∅	H1	H2	H3	L1	≅	Peso/unidad	Nº art.	Tipo	PE <sup>1)</sup>
D1	[pulgadas]	D2							[oz]			
Rosca UNF												
10-32	0,098	1/8	7,6	15,3	3,6	-	13,5	5/16	0,071	533285	QBML-10-32-UNF-1/8-U	10
	0,098	5/32	8,7	15,9	3,6	-	14,6	5/16	0,176	572308	QBML-10-32-UNF-5/32-U	10
	0,098	1/4	11,3	17,2	3,6	-	16,1	5/16	0,353	573059	QBML-10-32-UNF-1/4-U	10
Rosca NPT												
1/8	0,098	1/8	7,6	15,8	8,5	11,7	13,5	7/16	0,176	533289	QBML-1/8-1/8-U	10
	0,118	1/4	11,3	17,7	8,5	13,6	16,1	7/16	0,564	573060	QBML-1/8-1/4-U	10
1/4	0,098	1/8	7,6	18,3	10,5	12,5	13,5	9/16	0,282	572310	QBML-1/4-1/8-U	10
	0,118	1/4	11,3	20,2	10,5	14,4	16,1	9/16	0,811	573061	QBML-1/4-1/4-U	10

1) Cantidad por unidad de embalaje

## Racor rápido roscado largo en L QBMLL

Rosca exterior  
con hexágono exterior

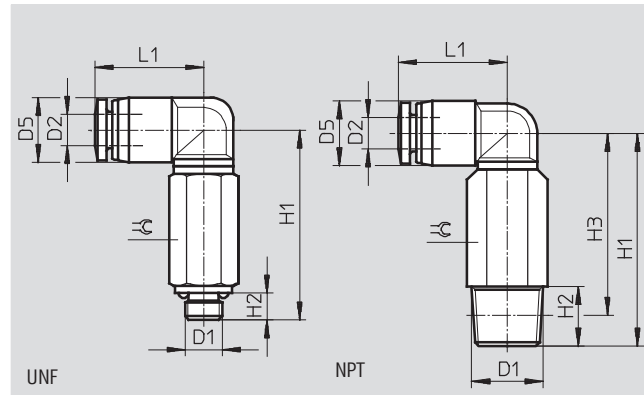

Dimensiones y referencias												
Conexión	Diámetro nominal	Para tubo de diámetro exterior	D5 ∅	H1	H2	H3	L1	≅	Peso/unidad	Nº art.	Tipo	PE <sup>1)</sup>
D1	[pulgadas]	D2							[oz]			
Rosca UNF												
10/32	0,098	1/8	7,6	23,9	3,6	-	13,5	5/16	0,282	572286	QBMLL-10-32-UNF-1/8-U	10
	0,098	1/4	11,3	28,7	3,6	-	16,1	5/16	0,317	573064	QBMLL-10-32-UNF-1/4-U	10
Rosca NPT												
1/8	0,098	1/8	7,6	24,4	8,5	20,3	13,5	7/16	0,388	572287	QBMLL-1/8-1/8-U	10
	0,118	1/4	11,3	32,7	8,5	28,6	16,1	7/16	0,494	573065	QBMLL-1/8-1/4-U	10

1) Cantidad por unidad de embalaje

## Racores rápidos roscados QBM, Quick Basic, mini, NPT

Hoja de datos

Racor rápido en L, QBML-...T

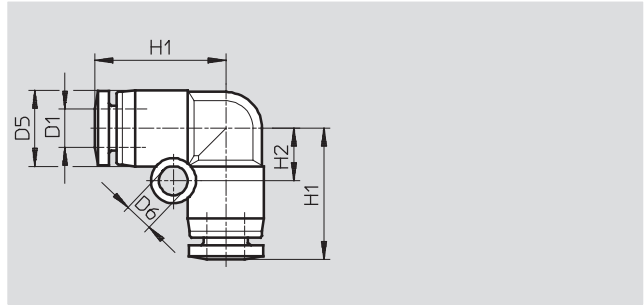

Dimensiones y referencias									
Para tubo de diámetro exterior D1	Diámetro nominal [pulgadas]	D5 ∅	D6 ∅	H1	H2	Peso/ unidad [oz]	Nº art.	Tipo	PE <sup>1)</sup>
1/8	0,094	7,5	3,2	13,5	5,4	0,071	572284	QBML-1/8T-U	10
5/32	0,118	8,4	3,2	14,5	5,8	0,106	572285	QBML-5/32T-U	10
1/4	0,197	11,2	3,3	17,6	7,0	0,176	573063	QBML-1/4T-U	10

1) Cantidad por unidad de embalaje

# Racores rápidos roscados QBM, Quick Basic, mini, NPT

Hoja de datos

## Racor rápido roscado en T, QBMT

Rosca exterior  
con hexágono exterior

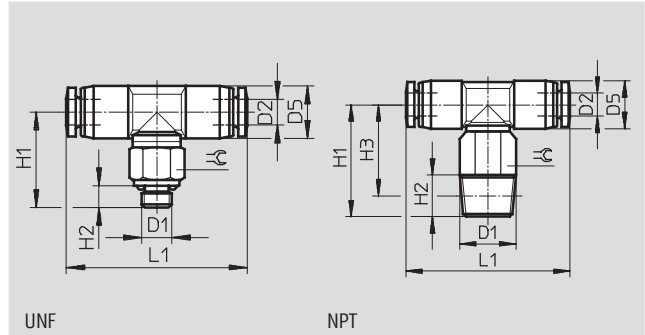

Dimensiones y referencias												
Conexión	Diámetro nominal	Para tubo de diámetro exterior	D5	H1	H2	H3	L1	⌀	Peso/ unidad	Nº art.	Tipo	PE <sup>1)</sup>
D1	[pulgadas]	D2	∅						[oz]			
Rosca UNF												
10-32	0,098	1/8	7,6	15,3	3,6	11,7	29,0	5/16	0,071	533304	QBMT-10-32-UNF-1/8-U	10
	0,098	5/32	8,7	15,9	3,6	12,3	30,2	5/16	0,088	572289	QBMT-10-32-UNF-5/32-U	10
	0,098	1/4	11,3	17,2	3,6	13,6	32,2	5/16	0,353	573067	QBMT-10-32-UNF-1/4-U	10
Rosca NPT												
1/8	0,098	1/8	7,6	15,8	8,5	11,7	29,0	7/16	0,176	533308	QBMT-1/8-1/8-U	10
	0,098	1/4	11,3	17,7	8,5	13,6	32,2	7/16	0,423	572291	QBMT-1/8-1/4-U	10
1/4	0,138	1/8	7,6	18,3	10,5	12,5	29,0	9/16	0,564	573068	QBMT-1/4-1/4-U	10

1) Cantidad por unidad de embalaje

## Racores rápidos roscados QBM, Quick Basic, mini, NPT

Hoja de datos

### Racor rápido en T, QBMT-...T

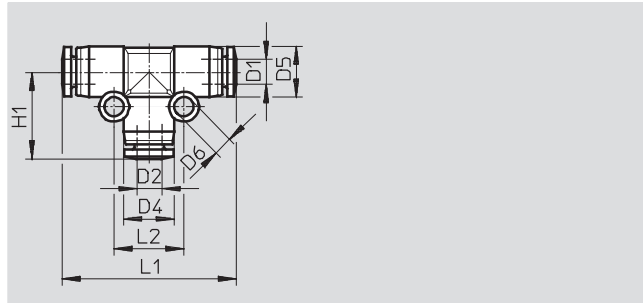
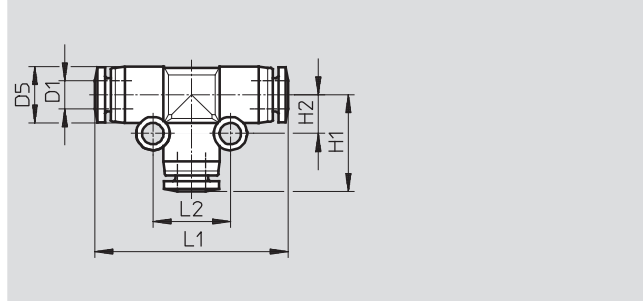

Reductor

Dimensiones y referencias												
Para tubo de diámetro exterior D1	Diámetro nominal [pulgadas]	Para tubo de diámetro exterior D2	D4 Ø	D5 Ø	D6 Ø	H1	L1	L2	Peso/ unidad [oz]	Nº art.	Tipo	PE <sup>1)</sup>
1/8	0,094	-	-	7,5	3,2	13,5	27,0	10,8	0,106	572293	QBMT-1/8T-U	10
5/32	0,118	-	-	8,4	3,2	14,5	29,0	11,6	0,141	572294	QBMT-5/32T-U	10
1/4	0,197	-	-	11,2	3,3	17,6	35,2	14,0	0,212	573069	QBMT-1/4T-U	10
Reductor												
5/32	0,094	1/8	8,4	8,4	3,2	14,4	14,5	5,8	0,141	572292	QBMT-5/32T-1/8-U	10
1/4	0,118	5/32	11,2	11,2	3,3	17,6	17,6	7,0	0,176	573070	QBMT-1/4T-5/32-U	10

1) Cantidad por unidad de embalaje

# Racores rápidos roscados QBM, Quick Basic, Mini, NPT

Hoja de datos

## Racor rápido roscado en T, QBMTL

Rosca exterior

con hexágono exterior

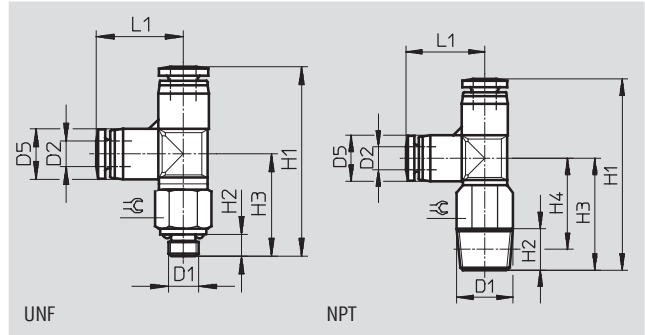

Dimensiones y referencias													
Conexión	Diámetro nominal	Para tubo de diámetro exterior	D5	H1	H2	H3	H4	L1	≈	Peso/ unidad	Nº art.	Tipo	PE <sup>1)</sup>
D1	[pulgadas]	D2	∅							[oz]			
Rosca UNF													
10-32	0,098	1/8	7,6	28,9	3,6	15,3	11,7	13,6	5/16	0,071	572295	QBMTL-10-32-UNF-1/8-U	10
	0,098	5/32	8,7	30,4	3,6	15,9	12,3	14,5	5/16	0,176	572296	QBMTL-10-32-UNF-5/32-U	10
	0,098	1/4	11,2	35,0	3,6	17,1	13,5	17,9	5/16	0,353	573071	QBMTL-10-32-UNF-1/4-U	10
Rosca NPT													
1/8	0,098	1/8	7,6	29,4	8,5	15,8	11,7	13,6	7/16	0,176	572297	QBMTL-1/8-1/8-U	10
	0,098	1/4	11,2	35,5	8,5	17,6	13,5	17,9	7/16	0,423	572298	QBMTL-1/8-1/4-U	10
1/4	0,118	1/8	7,6	31,9	10,5	18,3	12,5	13,6	9/16	0,564	573072	QBMTL-1/4-1/8-U	10

1) Cantidad por unidad de embalaje

## Racores rápidos roscados QBM, Quick Basic, mini, NPT

Hoja de datos

### Racor rápido en Y, QBM...T

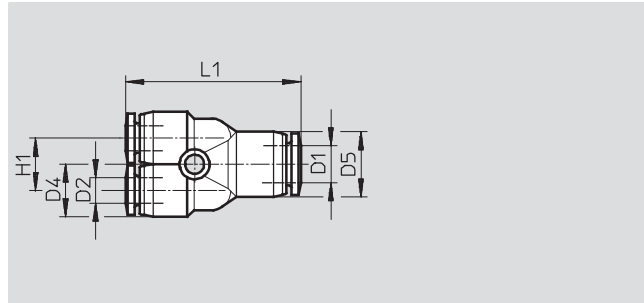
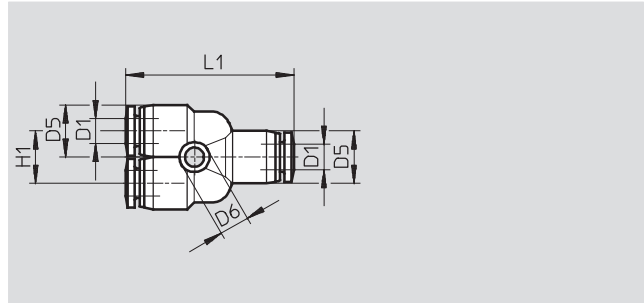

Reductor

Dimensiones y referencias											
Para tubo de diámetro exterior D1	Diámetro nominal [pulgadas]	Para tubo de diámetro exterior D2	D4 Ø	D5 Ø	D6 Ø	H1	L1	Peso/ unidad [oz]	Nº art.	Tipo	PE <sup>1)</sup>
1/8	0,094	-	-	7,6	3,2	7,6	26,8	0,141	572299	QBM-1/8T-U	10
5/32	0,118	-	-	8,7	3,2	8,7	28,0	0,106	572300	QBM-5/32T-U	10
1/4	0,197	-	-	11,3	3,2	11,3	32,6	0,176	573073	QBM-1/4T-U	10
Reductor											
1/8	0,094	5/32	7,6	8,7	3,2	7,6	27,5	0,141	572301	QBM-5/32T-1/8-U	10
5/32	0,118	1/4	8,7	11,3	3,2	8,7	29,8	0,176	573074	QBM-1/4T-5/32-U	10

1) Cantidad por unidad de embalaje





# Suministros Industriales del Tajo, S.A.

C/ Jarama 52, Polígono Industrial, 45007 Toledo (Spain)

Telf: (34) 925 23 22 00

Fax: (34) 925 23 21 47

[sitasa@sitasa.com](mailto:sitasa@sitasa.com)

[www.sitasa.com](http://www.sitasa.com)

